

# THE JOINT EXAMINATION BOARD PAPER P3-1997

## PREPARATION OF SPECIFICATIONS

Friday, 7<sup>th</sup> November 1997

10:00 a.m. - 2:00 p.m.

Please read the following instructions carefully. This is a **FOUR HOUR** paper.

1. Check the contents of this envelope. You should have *two (2) sheets* of question paper including these instructions and *two (2) sets of the drawings* each set being of *five (5) numbered sheets*.
2. In the appropriate boxes at the top of each sheet please enter the designation of the paper (P3), the question number and your examination number. You should write only on one side of the paper using **BLACK** ink. Please do **NOT** staple pages together. You should **NOT** write your name anywhere in the answers.
3. **NO** printed matter or other written material may be taken into the examination room.
4. Answers **MUST be legible**. If the examiners cannot read a candidate's answer then no marks will be awarded.

...ooo0ooo...

12 PAGES, INCLUDING THIS PAGE

Your client writes: --

We have, as you know, produced a trolley for some time in which the wheels at the base of the trolley are each substituted by a tri-lobal spider each lobe of which carries a wheel. The spider is pivoted at its centre and is capable of rotation about its pivot. These trolleys, shown in Figures 1 and 2, have been very successful and are particularly useful because of their ability to negotiate small steps or kerbs. In use, when carrying a load, the trolley is backed against kerbs until the rear-most wheel contacts the edge of the kerb. Pulling on the handle causes the spider to rotate relative to the body of the trolley so that the upper wheel moves into contact with the upper surface of kerb. Further rearward motion will bring another of the wheels also into contact the upper surface of the kerb and allow continued movement of the loaded trolley.

A disadvantage of this arrangement is that, when the trolley is heavily loaded and the kerb is relatively high, the effort required to lift the pivot of the spider "Over centre" is quite considerable. The mechanical advantage inherent in the device is relatively small.

We have sought to overcome this problem by providing a much more flexible arrangement. The accompanying drawings Figures 3 to 9 show a modification of the trolley of Figures 1 and 2. A significant advantage of this arrangement is the reduction of moving parts in the new trolley results in a product cheaper to manufacture. We have modified the device by the provision of a removable castor towards the handle portion of the trolley. This allows the trolley to be laid flat so that it is supported in three or four positions and the back of the trolley becomes a load bearing platform. We have called this a "trundle-humper". We can also provide a folding handle or end arm to assist in manipulation and movement of the trundle-humper for translational movement across a surface.

When the trundle-humper approaches kerb, the obstacle can be negotiated in the manner showed in the sequence of Figures 5 to 8. It will be appreciated that the mechanical advantage provided by the length of the back of the trolley will make the task of lifting a significant weight over a kerb much easier.

We believe that our new design is a significant improvement and will enable us to provide a superior and more flexible product at a much more competitive price. We see a market for this product and we shall be pleased if you will prepare and file as soon as possible an application in the Patent Office.

Draft a patent specification and claims (but without abstract) for filing in the United Kingdom Patent Office.

Marks will be allocated as follows: -

Preamble	15 marks
Specific description	25 marks
Claims	60 marks

...ooo0ooo...

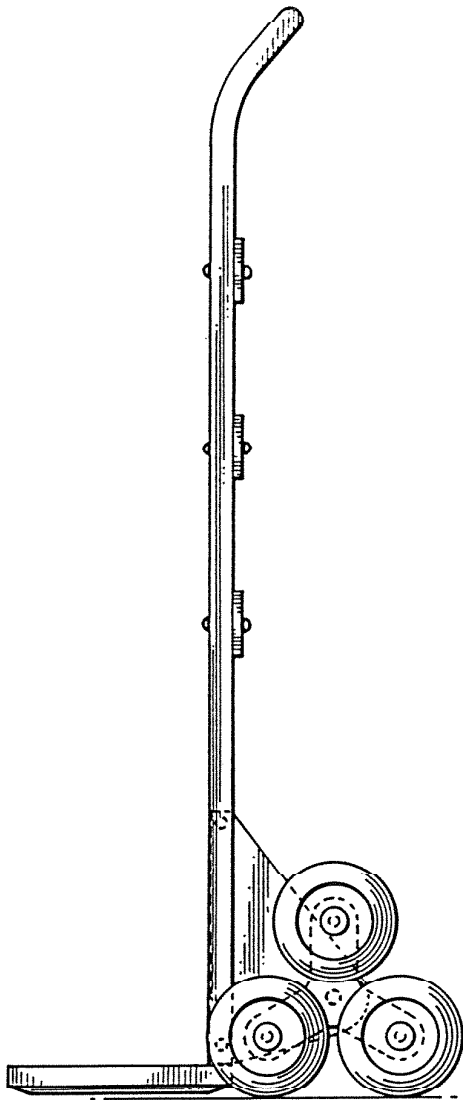

Figure.1  
(Prior Art)

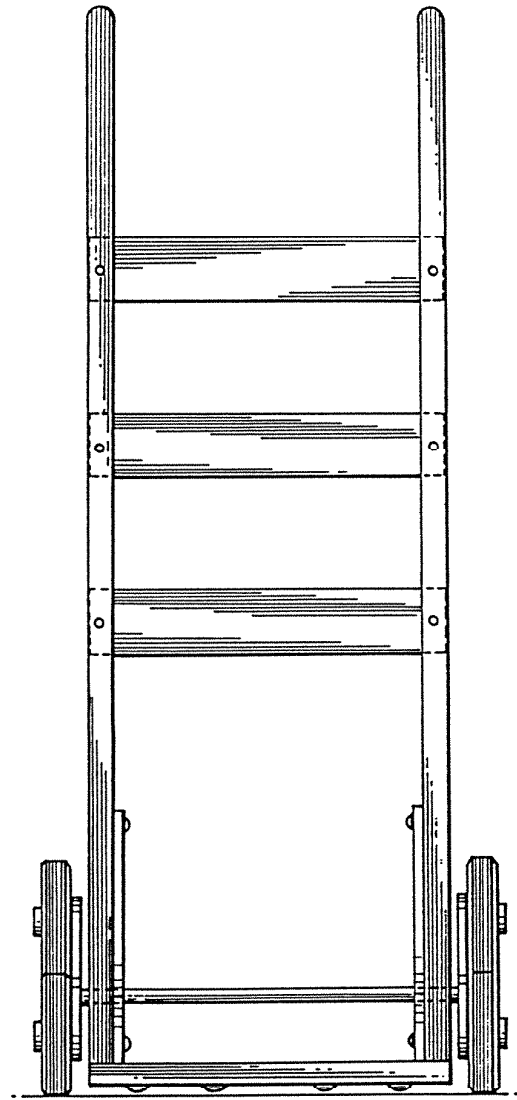
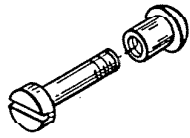

Figure.2  
(Prior Art)



FIXING B.

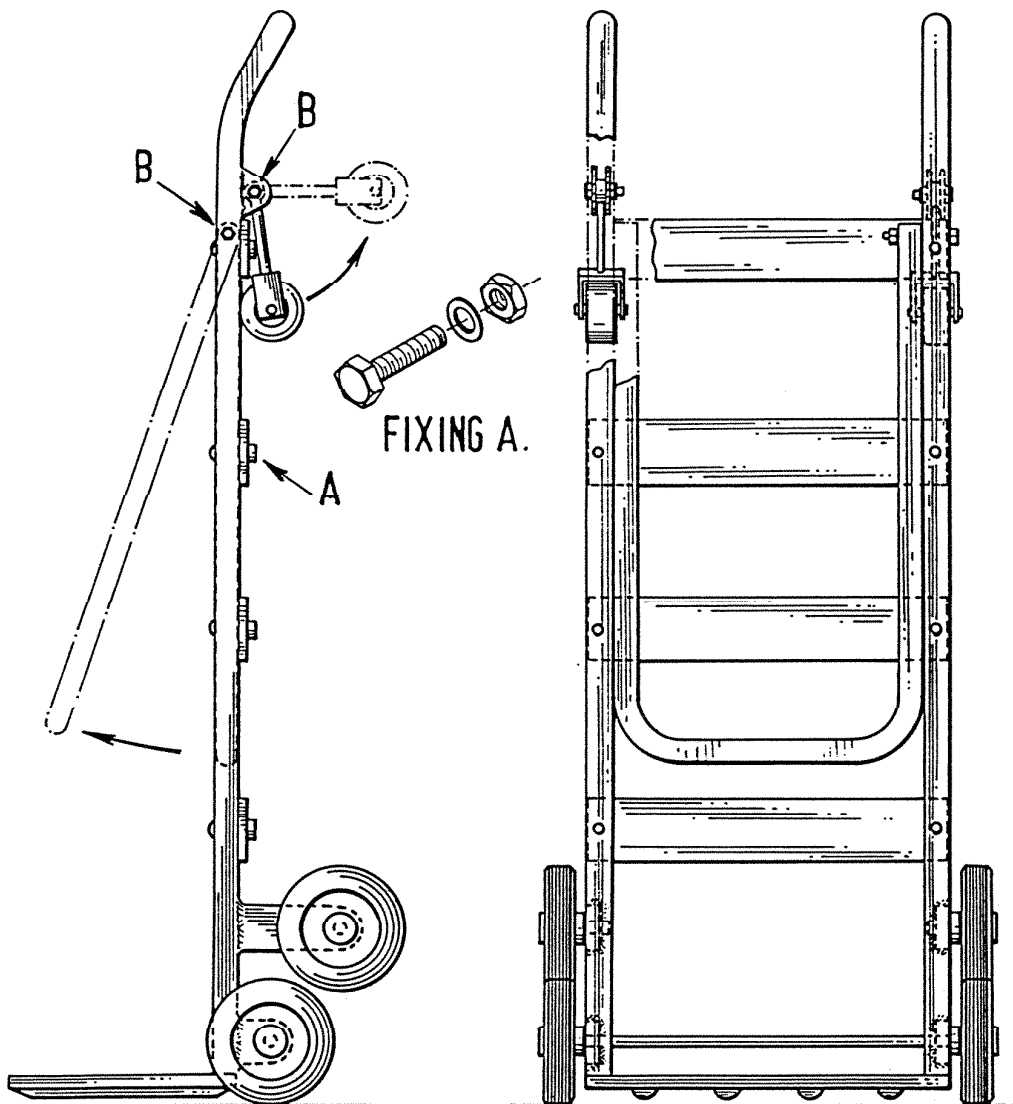

Figure.3

Figure.4

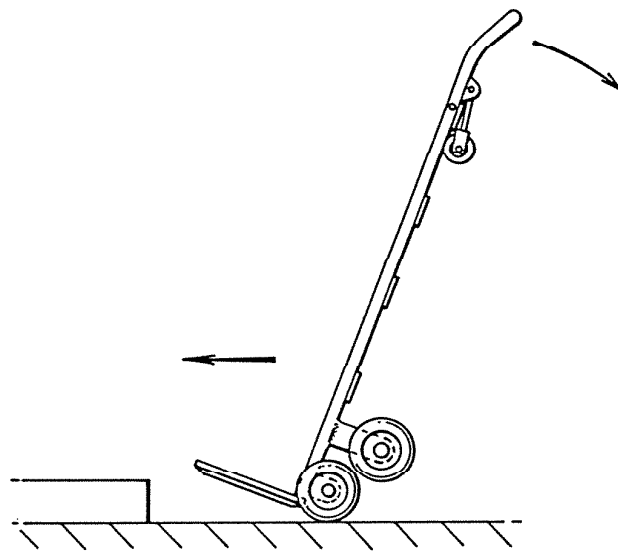

Figure.5

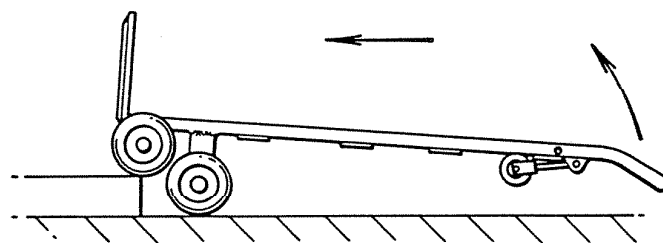

Figure.6

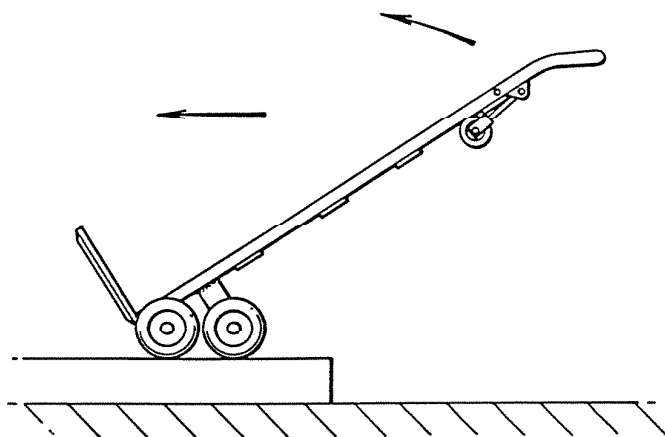

Figure.7

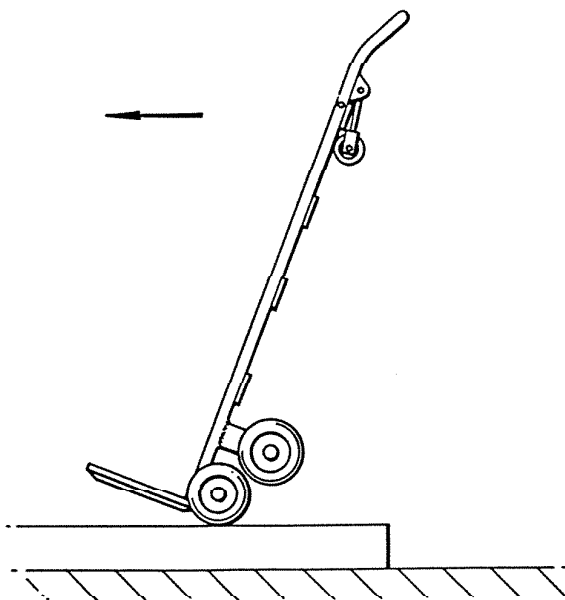

Figure.8

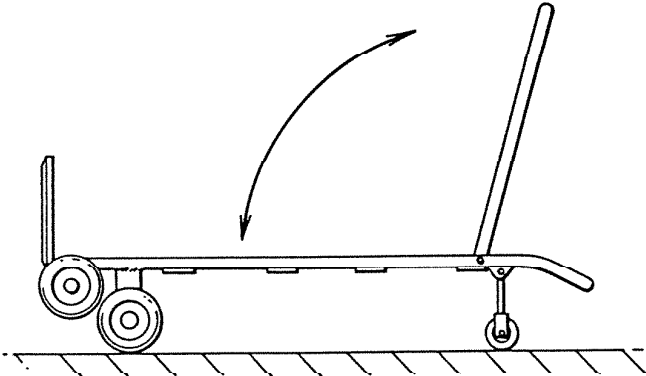

Figure.9

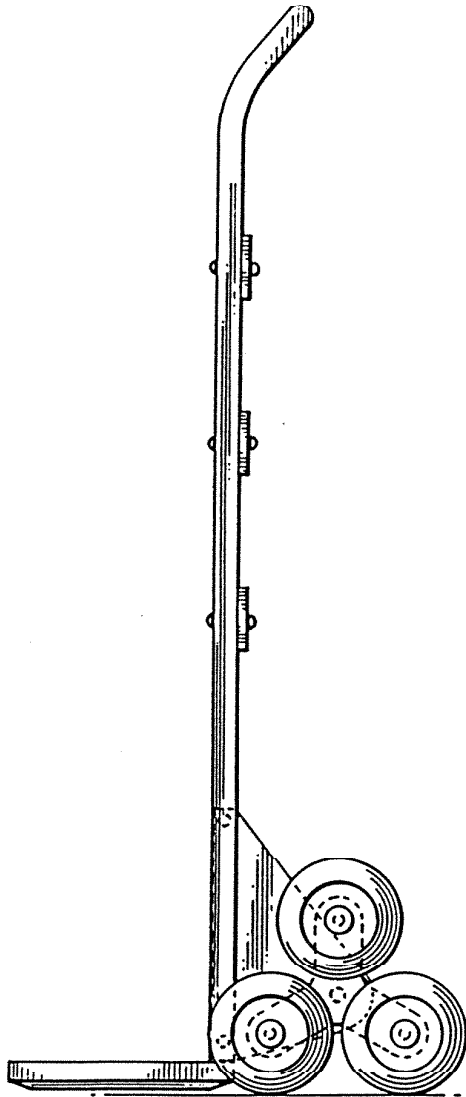

Figure.1  
(Prior Art)

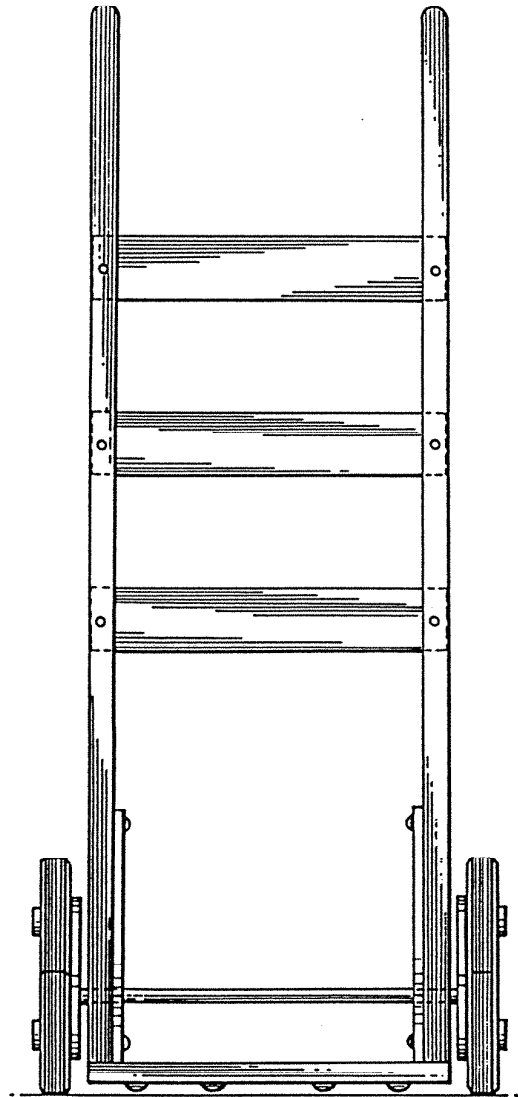
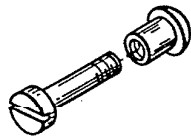

Figure.2  
(Prior Art)



FIXING B.

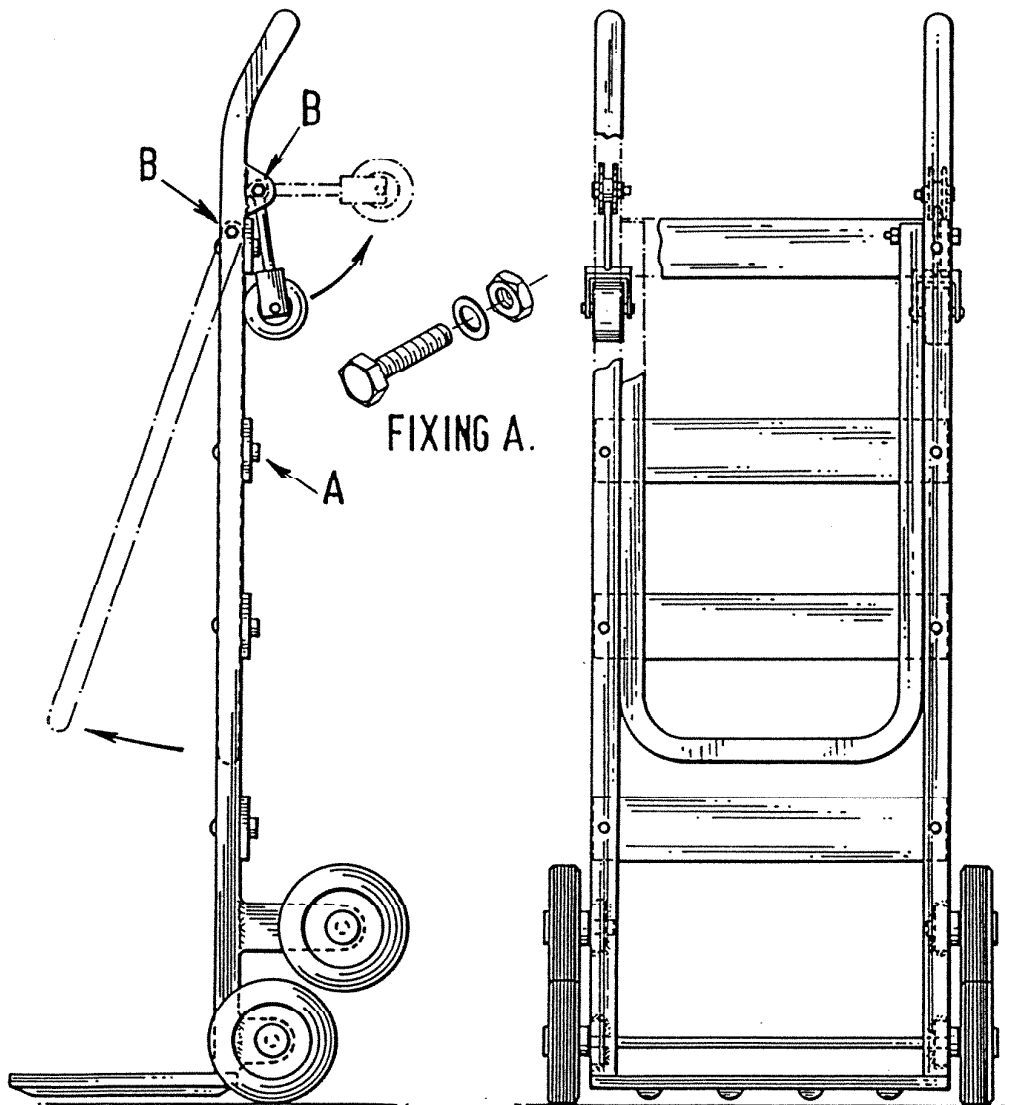

Figure.3

Figure.4

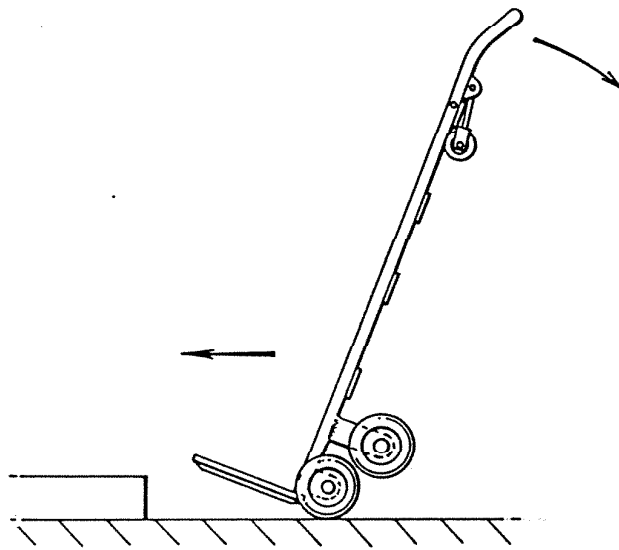

Figure.5

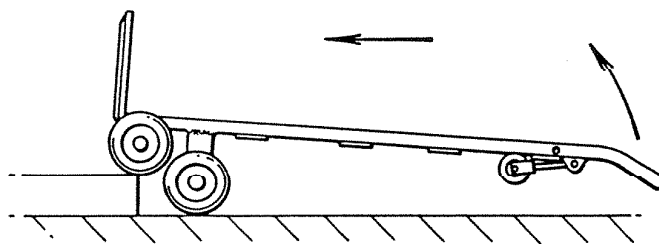

Figure.6

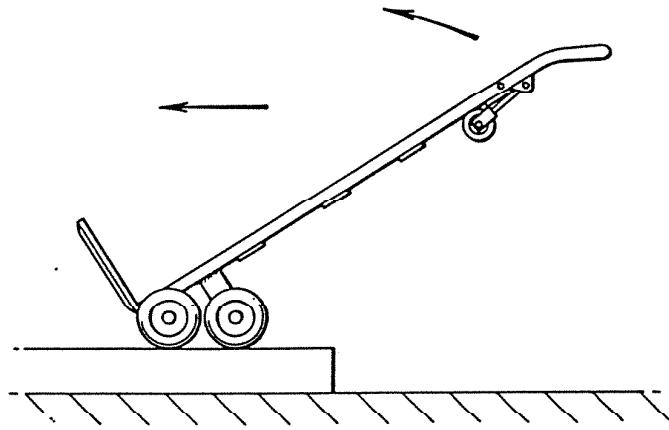

Figure.7

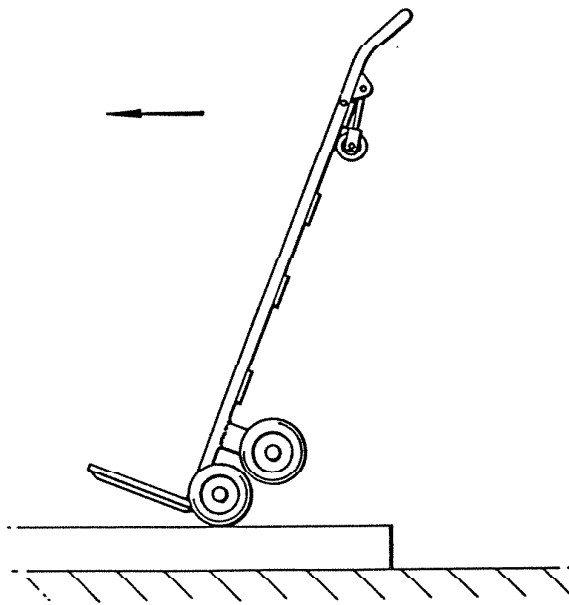

Figure.8

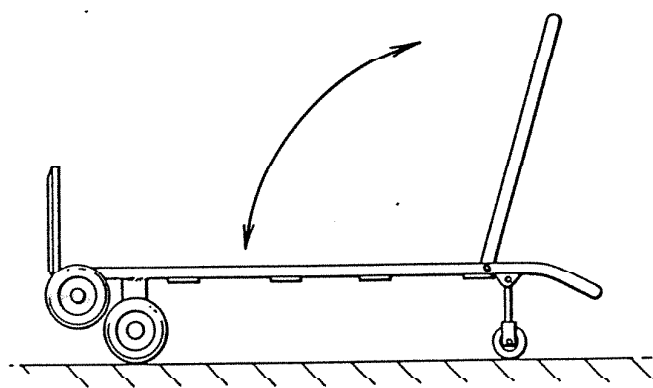

Figure.9