

THE JOINT EXAMINATION BOARD

PAPER P3

PREPARATION OF SPECIFICATIONS

12th November 1999

10:00 a.m. – 2:00 p.m.

Please read the following instructions carefully. This is a **FOUR HOUR** paper.

1. Check the contents of this envelope, You should have **three (3) sheets** of question paper including these instructions and two (2) **sets** of the drawings each set being of **three (3) numbered sheets**.
2. In the appropriate boxes at the top of each sheet please enter the designation of the paper (P3), the question number and your examination number. You should write only on one side of the paper using **BLACK** ink. Please do **NOT** staple pages together. You should **NOT** write your name anywhere in the answers.
3. **NO** printed matter or other written material may be taken into the examination room.
4. Answers **MUST be legible**. If the Examiner cannot read a candidate's answer then no marks will be awarded.

This paper consists of **SIX** pages including this page.

Your client, a plastics moulding manufacturer, writes:

“For many years we have manufactured flip-top dispensers for small mint sweets, artificial sweeteners and the like. There are several different types of such dispenser but they are all fairly crude and essentially comprise a box having a releasably closeable aperture which is opened in order to allow the contents to be discharged through the open lid by tipping up the dispenser.

One example, marked as “Prior Art” is shown, and comprises a generally rectangular plastics box, in an open end of which is secured a plastics top or plug having a hinged lid which can simply be clicked open and shut by finger pressure.

There are many disadvantages associated with such dispensers, including the need to use two hands for reliable dispensing of the contents. Moreover, the known dispensers suffer from the drawback that as the dispenser is tipped up, it is difficult to control the number of items to be dispensed. This is of particular concern to the use of such dispensers by elderly or infirm people, particularly because the items to be dispensed are in themselves often very small.

The problem can be overcome to some extent by reducing the size of the dispensing aperture, but it then becomes increasingly difficult to dispense the items reliably when required.

There is also the problem that if too many items are dispensed, an attempt is normally made to return the excess items to the dispenser, which can be both troublesome and unhygienic.

We have devised a dispenser which allows virtually foolproof one-handed dispensing of small items one at a time.

The dispenser has a generally rectangular moulded plastics housing open at one end and having a dispensing aperture at the opposite end. A hopper is slidably mounted in the housing and can be depressed in order to dispense a single item from the dispenser.

The hopper has a downwardly-depending dispensing portion which is open along one edge and which, in combination with the adjacent side wall of the housing, defines a channel of such a width that only a single item at a time engages its base wall, which is inclined upwardly. The depth of the channel (from front to back) is chosen to be just slightly larger than the depth of the items to be dispensed, so that the items can only enter the channel “edge-on”, as shown in the drawings. Several individual items are thereby stacked one on top of another in the channel.

As the hopper is depressed to its maximum extent (as determined by a stop projecting from the underside of the hopper), the lowermost item within the dispenser slides off the base wall and passes out through the discharge aperture . The next lowermost item is prevented from being discharged by a neck portion of reduced width which, when located adjacent to the discharge aperture, forms a gap which is smaller than the width of the item.

As the hopper is depressed, an integrally formed spring portion is deformed against the base wall of the housing, which returns the hopper to its starting position when finger pressure is removed. The hopper is prevented from sliding out of the housing by means of a retaining lip on the dispensing portion, which engages underneath a second lip along one edge of the dispensing aperture.

Thus reliable, one-handed and hygienic dispensing of individual articles can be performed by a simple pressing action with one finger.

The design allows us to form the dispenser from only two mouldings, which can be assembled extremely easily simply by inserting the filled hopper into the housing and clicking it into place.”

-
1. Draft an introduction, including a review of prior art and statement of invention, up to but not including the list of figures. (30 marks)
 2. Draft claims for a United Kingdom Patent Application. (70 marks)

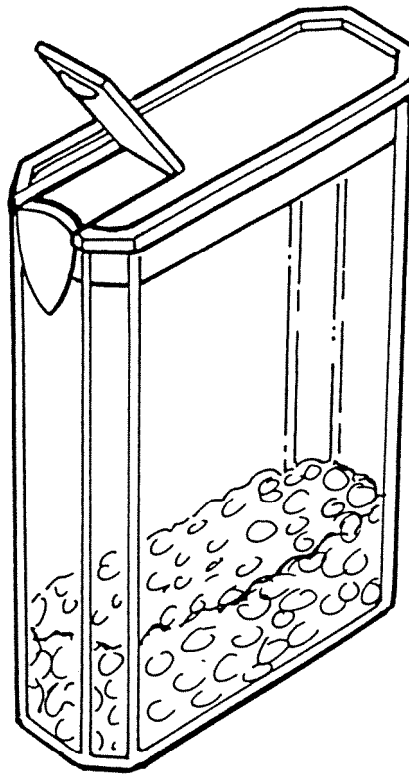

PRIOR ART

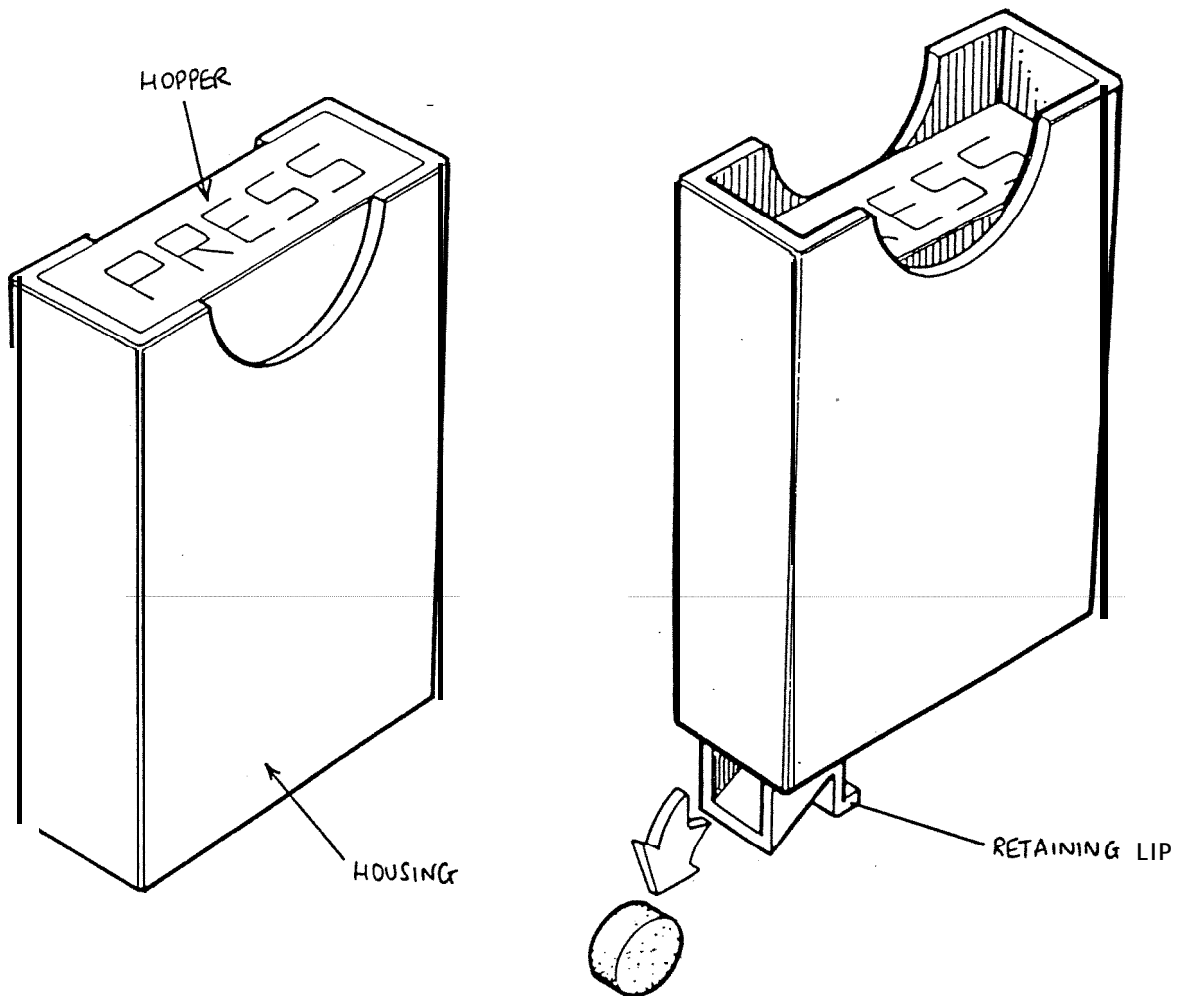

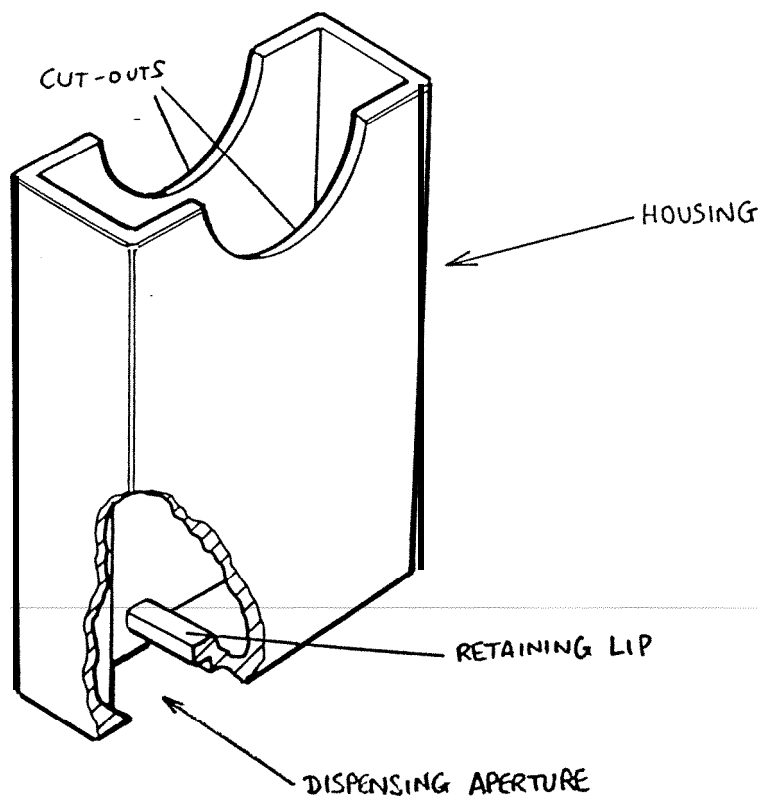
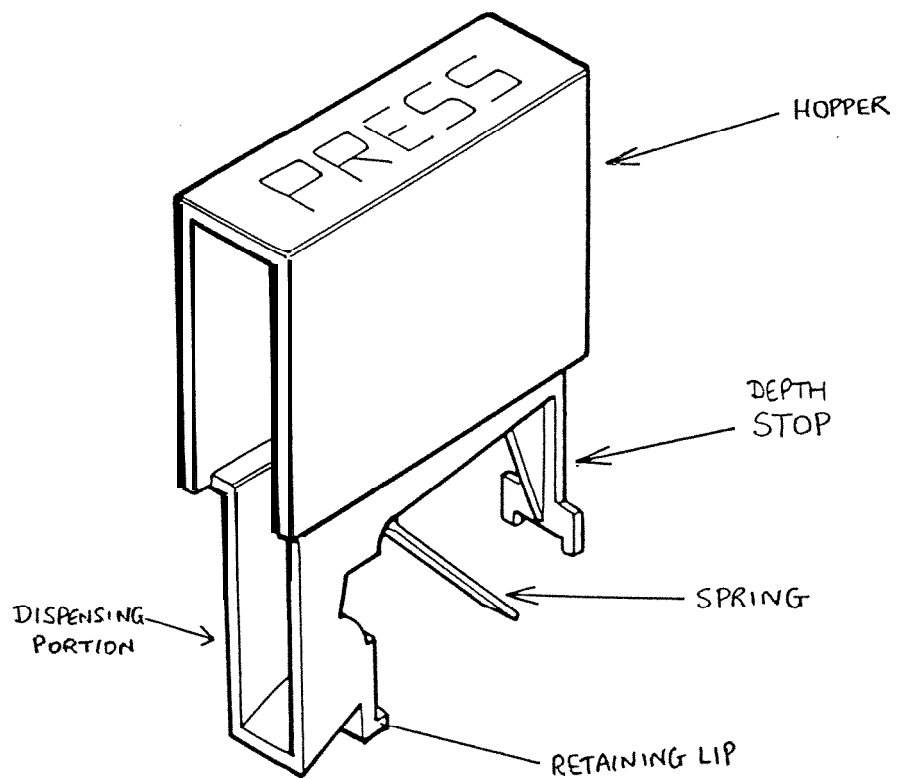

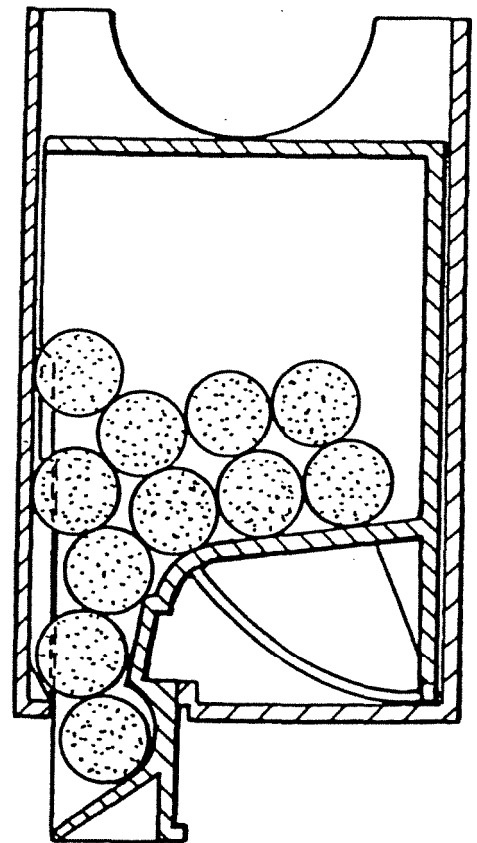
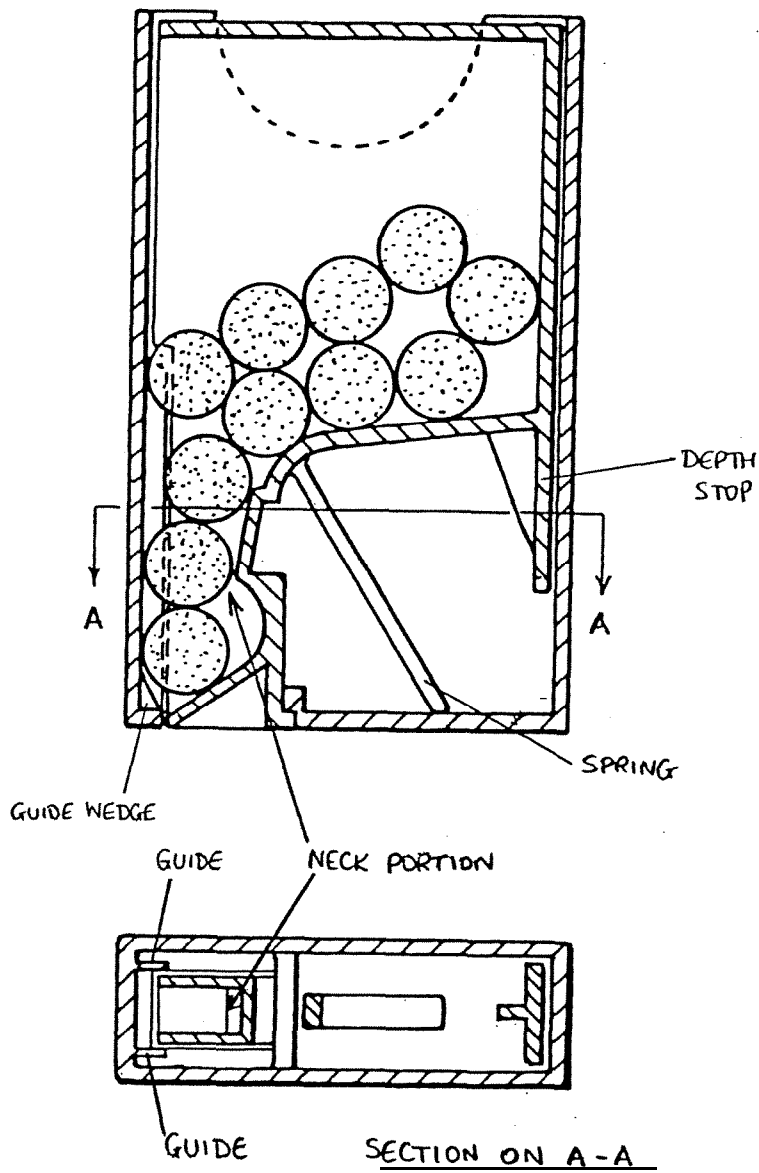

DRAFTING – PAPER P3
EXAMINERS' COMMENTS

Usually these comments mention how poorly was answered the question, generally speaking. This year is no exception. The principal reason for failure was that candidates did not get under the article before them and see the underlying invention, but rather claimed the article they saw. In addition the paper was too often treated as an academic exercise in which the candidate appeared to feel it necessary to show that he could draft all kinds of method claim as well as article claims. If the paper gave him pictures of a prior art device, then he (including she) felt he should use that drawing in the answer. Many answers did not betray an understanding of what kind of advantages the construction of the invention afforded the manufacturer as distinct from the user.

The Patent Attorney operates at the interface between technology, law and commerce, and the candidate who satisfies the Examiners that he is ready to be allowed to practise in his own name will demonstrate, in his answers to these finals questions, that he has the necessary nous in all three areas. Simple mechanical devices are accordingly used in the exams and good marks get awarded to those candidates who see the invention lying behind the device presented to them, perhaps because they readily perceive another way in which the invention can be realised. Thus for example, good marks were awarded to the candidate who in particular drew our attention to the possibility of a rotary device fulfilling the objectives of the invention. You could imagine even a Rubric Cube kind of dispenser!

Accordingly a very good main claim was one which claimed a housing and a hopper **moveably** co-operating with one another to contain a quantity of a material and when so moved to dispense a predetermined quantity of the contents.

In this way also, the possibility that a fluid or powder might be the content was covered, and one or two candidates did this, whether by accident or design being immaterial. A subsidiary claim could have called for a delivery antechamber, before we got into claims covering the particular device the client was concerned with.

Although quite a few candidates were careful that their main claim was not limited to the dispensing of a single item, this being retained for a subsidiary feature, upon reflection this was probably not so very important. Dispensing a single item allows the user to select exactly how many of the items to dispense on any one occasion.

Candidates who included biasing means in their main claim accordingly failed, except when they included two or more independent claims to the article, one to a dispenser having biasing means, another to the antechamber feature. Candidates should remember that the facility of including a plurality of independent article claims is available to them at the beginning of the patenting process. One candidate actually managed quite a good pass whilst not mentioning biasing means anywhere in his answer!

Notes to the Examiners almost never earn marks, particularly when they say things like “I have drafted a broad claim in order to draw a wide search”. One candidate who did this submitted one of the narrower of the failed claims. Candidates might bear in mind that the Examiners are very experienced Patent Attorneys who need little guidance to perceive the kind answer which demonstrates a candidate fit to be let loose on the public in his/her own right. On the other hand with such experience comes age and deteriorating eyesight. Clear writing, on every other line, one new page for every new claim, helps us as well as permitting the candidate space to revise his answer. Nevertheless (or consequently) the P3 Examiners will not be seeing again an answer from the candidate whose lettering was, except for tall ones like “d” and “t”, somewhat less than 2mm high!

As intimated above, quite a lot of candidates included claims to a method of dispensing. This might be justifiable where their article claim had managed to cover other than a hand-held or pocket device. Many candidates however did not find a way of trying a claim to making and assembling the dispenser. Claims to manufacturing in two parts, filling and “snapping” closed, were rewarded by the Examiners. Too often candidates did not appear to realise the considerable value and importance of being able to manufacture the dispenser from one raw material, with only two mouldings. The biasing means being integral with the hopper was an important clue to this, and it is quite realistic for an inventor to present a drawing **such as** was given here, and not to draw attention to this immense advantage.

Too many candidates included highly unnecessary limitations like “rectangular”, “at one end”, “hand-held” and “downwardly dependant”, in their main claim.

Candidates should also not underestimate the importance of subsidiary claims. A less than ideal broad main claim can be, and in some cases was, complemented by **well-**drafted subsidiary claims to such an extent as to merit a pass. Conversely, borderline main claims were in some cases let down by poor subsidiary claims to such an extent that insufficient marks were gained to merit a pass.”

Turning to the Preamble, by which the Examiners mean all the specification leading to but excluding the particular description, (and excluding the Abstract) many candidates saw fit to include a description referring to drawings of the prior art device. We would not have thought that a probably well known and very simple article would require this, and wiser candidates did not refer to such drawings. Note however that this was not a failing, rather an extent of passing or failing, matter. Some candidates rather inappropriately employed **terms such as** “crude”“-in their-specification **to describe** the prior art device, and many misused the “two hands” problem.

The Examiners were looking for an argument, sustained throughout the preamble, which justified every aspect of the invention, in other words, the basis for every claim.