

**THE JOINT EXAMINATION BOARD**

**PAPER P3**

**PREPARATION OF SPECIFICATIONS FOR UNITED KINGDOM AND OVERSEAS  
PATENTS**

**Friday 15th November, 2002**

**10.00 a.m. – 2.00 p.m.**

*Please read the following instructions carefully. Time Allowed – **FOUR HOURS***

1. The marks attributed to each part of this paper are shown.
2. Please note the following:
  - Enter the Paper Number, the question number and your Examination number in the appropriate boxes at the top of each sheet of paper
  - Write on one side of the paper only, within the printed margins using a **BLACK** pen.
  - **DO NOT** use coloured pens or highlighters within the answers – they will not photocopy.
  - **DO NOT** staple or join pages together in any way
  - **DO NOT** state your name anywhere in the answers
3. Your answer is **NOT** required in letter form.
4. **NO** printed matter or other written material may be taken into the examination room. **ALL** mobile phones and electronic aids **must** be switched off and stored away.
5. Answers **MUST** be legible. If the examiners cannot read a candidate's answer no marks will be awarded.
6. **NO WRITING OF ANY KIND WILL BE PERMITTED AFTER THE TIME ALLOTTED TO THIS PAPER HAS EXPIRED. At the end of the examination assemble your answer sheets in question number order and place in the WHITE envelope provided.**

This paper consists of five pages, including this page.

Your client writes:

"We have invented a new container loading system for lorry transport that we'd like you to patent for us.

Doubtless you have seen the traditional skip vehicles, where a trapezoidal skip having chain attachments at each of its top corners can be hoisted onto and off a lorry, the lorry having two hydraulically actuated arms, one on each side of the lorry chassis, to the ends of which the chains are attached; the skip has to be suspended, free of the ground, behind the lorry as it is being hoisted onto the lorry. The lorry has a strut attached near each back corner of the lorry chassis; these struts are lowered and locked against the ground to counter-balance the weight of the skip as it is being hoisted, otherwise the lorry would tip backwards.

In our system, as shown in the two diagrams, there is a single centrally mounted hook arm system, comprising a hook arm which at rest is just behind the cab, pivoted to a base arm which in turn is pivotally mounted to the lorry chassis. Hydraulic rams actuate between the hook arm and the base arm and between the base arm and the chassis to bring the hook to a position suspended behind the lorry. In this position the driver can back the lorry until the hook is below a bail bar on the front of the container and operate the hydraulics so that the hook engages the bail bar. Operation of the hook arm system first lifts the front of container, so that the back of the container pivots and slides forward on the ground. Continued operation brings the underside of the container against the rear of the lorry chassis, where-about it pivots and slides to the position shown in the first diagram. This movement brings the rear of the container up off the ground and the container then continues to pivot and slide forward over the chassis until it is fully home, as shown in the second diagram. Thus, the container is never suspended off the ground behind the lorry.

There is a rail along each side of the chassis, to support the container on the chassis and permit the hook arm system to fold down out of the way between the side rails when the container is fully home. There is also a set of rollers at the rear of the chassis and these serve to facilitate the loading and unloading, to align the container fully with the chassis and can also be arranged to maintain the position of the container on

the chassis when the lorry is being driven, particularly if locks (not shown) are not employed to lock the container to the chassis. The container may also have rollers or skids at its rear end so that it moves easily along the ground during loading/unloading and ground scouring can be minimised.

The hook's orientation, extending away from the hook bar as shown, enables driver only, rather than driver plus mate, operation. The driver can back the lorry to the A-frame of the container with the hook lower than the bail bar, this will ensure that the hook grabs the bail bar when the hydraulics are operated."

You are to draft a part patent specification, as detailed below, suitable for first filing at the UK Patent Office. Marks will be awarded as follows:

Preamble – up to before the description of the drawings 25%

Claims 75%

There is no need to prepare a specific description or an abstract.

(Additional documentation supplied – one set of diagrams)

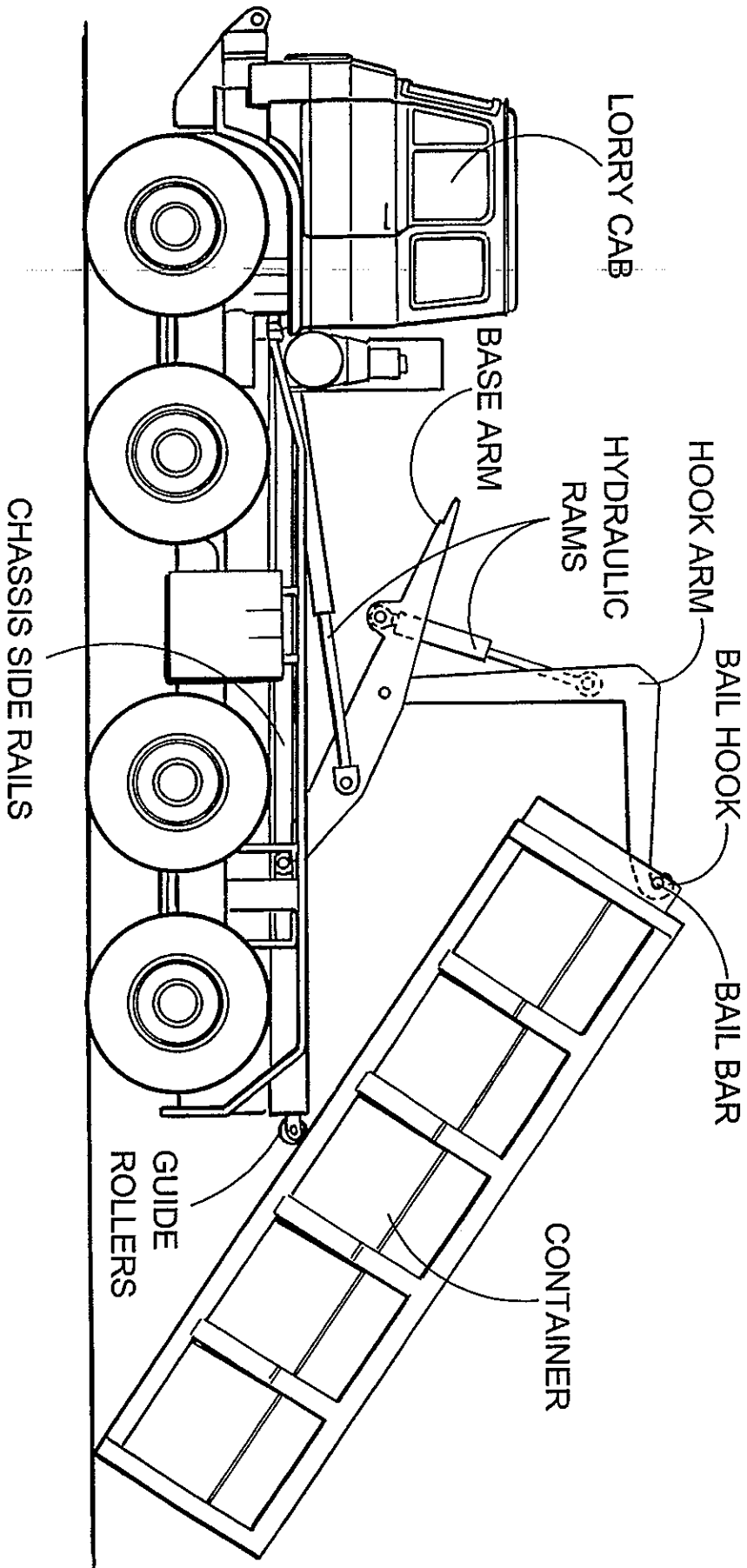

**FIG.1.**

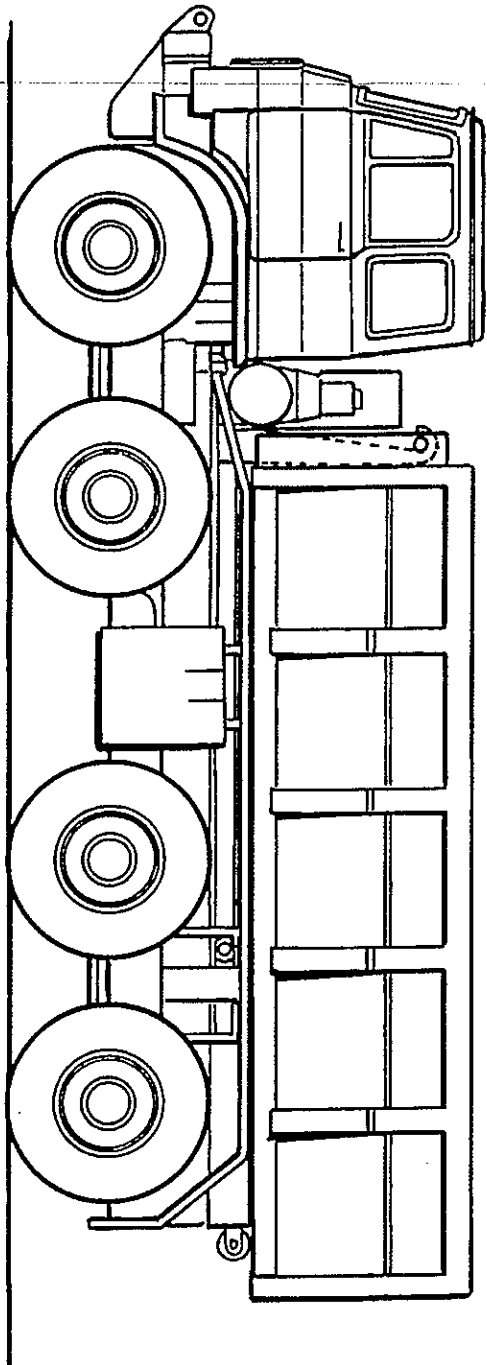

**FIG.2.**