

## THE JOINT EXAMINATION BOARD

## PAPER P3

5                    **Preparation of Specifications for United Kingdom and Overseas  
                         Patents**

**Friday, 7<sup>th</sup> November 2003**  
                         **10.00 a.m. – 2.00 p. m.**

10

*Please read the following carefully. Time Allowed – **FOUR HOURS***

15

1.        The marks attributed to each part of the paper are shown.

2.        Please note the following:

20

Enter the Paper Number and your Candidate number in the appropriate boxes at the top of each page or sheet.

Write on one side of the paper only, within the printed margins using a **BLACK** or **BLUE-BLACK** pen.

25

**DO NOT** use coloured pens or highlighters within the answers – they will not photocopy.

**DO NOT** staple or join pages or sheets together in any way.

**DO NOT** state your name anywhere in the answers.

30

3.        **Unless specifically requested answers are NOT required in letter form.**

4.        **NO printed matter or other written material may be taken into the examination room.**

**ALL mobile phones and electronic aids **must** be switched off and stored away.**

35

5.        Answers **MUST** be legible. If the examiners cannot read a candidate's answer no marks will be awarded.

40

6.        **NO WRITING OF ANY KIND WILL BE PERMITTED AFTER THE TIME ALLOTTED TO THIS PAPER HAS EXPIRED. At the end of the examination assemble your answer pages and sheets in order and place in the **WHITE** envelope provided.**

45

This paper consists of ten pages, including this page and comprising two pages of client's instructions and seven sheets of drawings.

Your client has e-mailed you the attached seven sheets of drawings.

5 Figures 1 (Sheet 1), 2 (Sheet 2), and 3 (Sheet 3) illustrate the invention, which is a clamping device for clamping a work piece to a bench or two or more work pieces together while they are being glued etc. He has labelled the parts of the device on the further copy of Figure 1 (Sheet 4).

10 The clamping device is clamped over a work piece by drawing the handles together. The serrated arcuate anchor plate, which is rigidly attached to the left hand handle, passes through a hole in a toggle plate which is pivoted about a fulcrum on the right hand handle. As the handles are drawn together, the toggle plate rocks about the fulcrum and against the toggle spring to index past successive ratchet serrations. When the work piece has been adequately gripped between the jaws, the handles can be released and the edge of the toggle plate hole catches on an appropriate anchor plate serration to hold the jaws in that configuration. When it is desired to release the work piece, the operator presses the toggle plate towards the right hand handle against the toggle spring. This releases the toggle plate from the anchor plate and frees the jaws to part again; a hidden spring acts to force the jaws apart. The clamping device can be operated with one hand.

20 Figure A (Sheet 5) shows a traditional G-clamp in which the mobile jaw member is screwed towards – and away from – the fixed jaw on the anvil member by turning the handle and screw thread; by this means work pieces can be clamped to one another or to a work bench. G-clamps require one hand to hold the anvil member steady whilst the handle is being turned.

25

30 Figures B (Sheet 6) and C (Sheet 7) illustrate a sealant gun used throughout the building and D-I-Y world to pump sealant from a sealant tube (shown in dotted form) whose nozzle projects through the base ring and whose rear piston which is a tight slide fit in the tube. When the sealant tube is fitted within the gun's sealant tube guides, the plunger plate can engage the tube's rear piston by pushing the plunger rod via the plunger handle. The plunger rod passes through a hole in a release toggle plate, which is pivoted about a

fulcrum at the rear of the gun, and can be then held in place by being frictionally gripped by an edge of the release toggle hole; the release toggle plate is urged backwards to a locking position by back-pressure from sealant in the tube acting against the tube's rear piston. To force sealant out of the sealant tube nozzle, the gun lever is pulled towards the fixed handle. By virtue of this action, the gun lever rotates clockwise about a pivot so that an actuator pin can engage a drive-toggle plate, loaded by a drive toggle spring, and pivoting about a fulcrum on the gun. The drive toggle plate frictionally grips the plunger rod and thereby urges the plunger plate into the sealant tube; the plunger rod riding through the release toggle hole during this action. When the gun lever is released, the drive toggle spring urges the drive toggle plate rearwards to free it from gripping the plunger rod; whilst the plunger rod is driven backwards by sealant back pressure and is frictionally gripped by the release toggle plate, to prevent it from withdrawing. Repeated pulling of the gun lever towards the fixed handle indexes the plunger rod into the sealant tube. When it is desired to withdraw the plunger rod, for example to remove the sealant tube, the operator depresses the release toggle plate and pulls back on the plunger handle. Alternative designs of sealant gun combine the release and drive toggle plates.

You realise that the sealant gun has essentially the same indexing and locking action as the clients' clamping device; even though the plunger rod has an hexagonal cross-sectioned, smooth-surfaced shape.

Your client is to exhibit the device at a D-I-Y exhibition which opens this evening, and you have accordingly to prepare and file a patent application at the UK Patent Office immediately.

Marks are awarded as follows:-

Preamble (specification up to the description of the Drawings):	20
Specific description with reference to Drawings; using Sheets 1, 2 and 3:	25
Claims:	50
Abstract	<u>5</u>
Total	100

Fig.1.

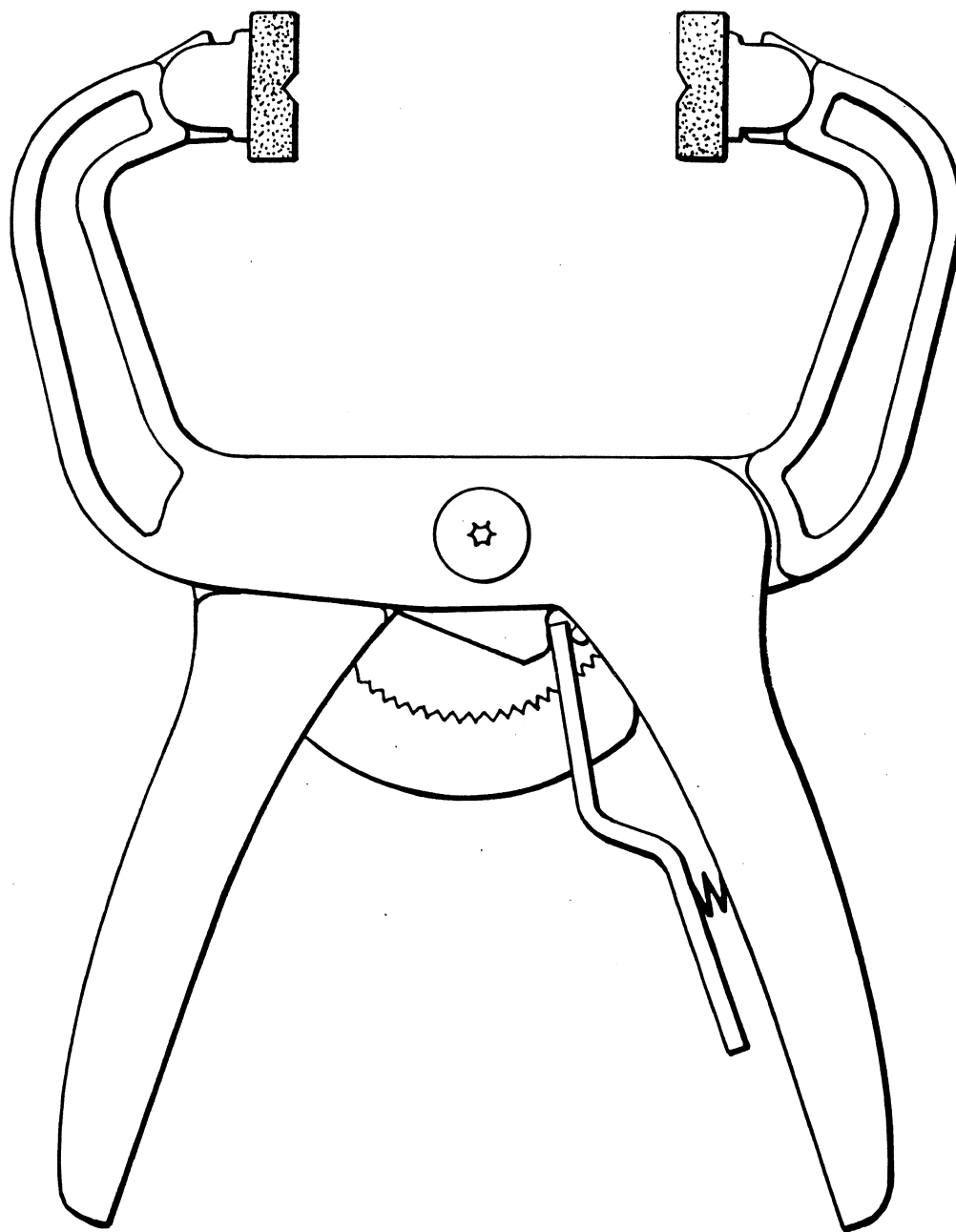
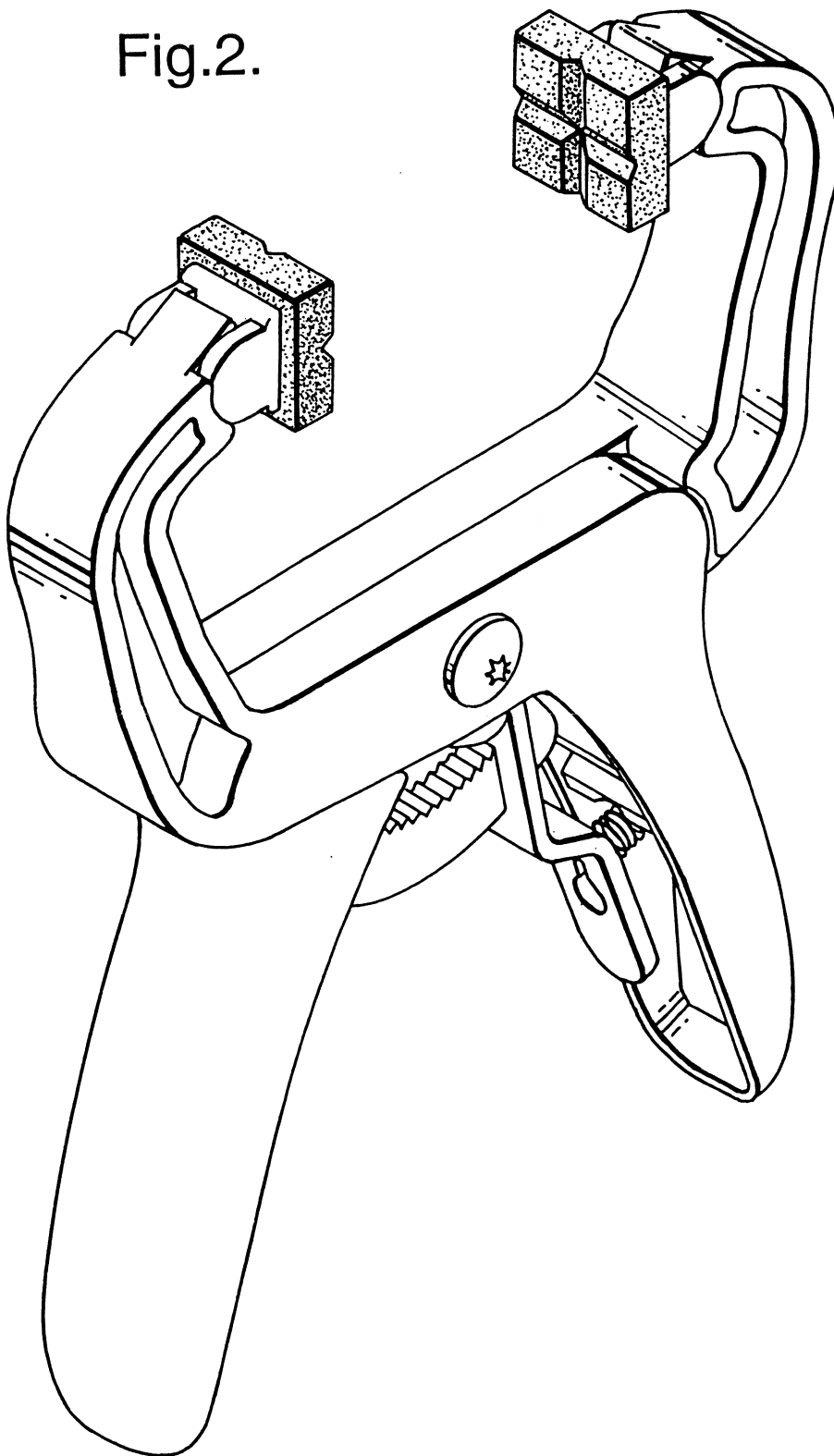
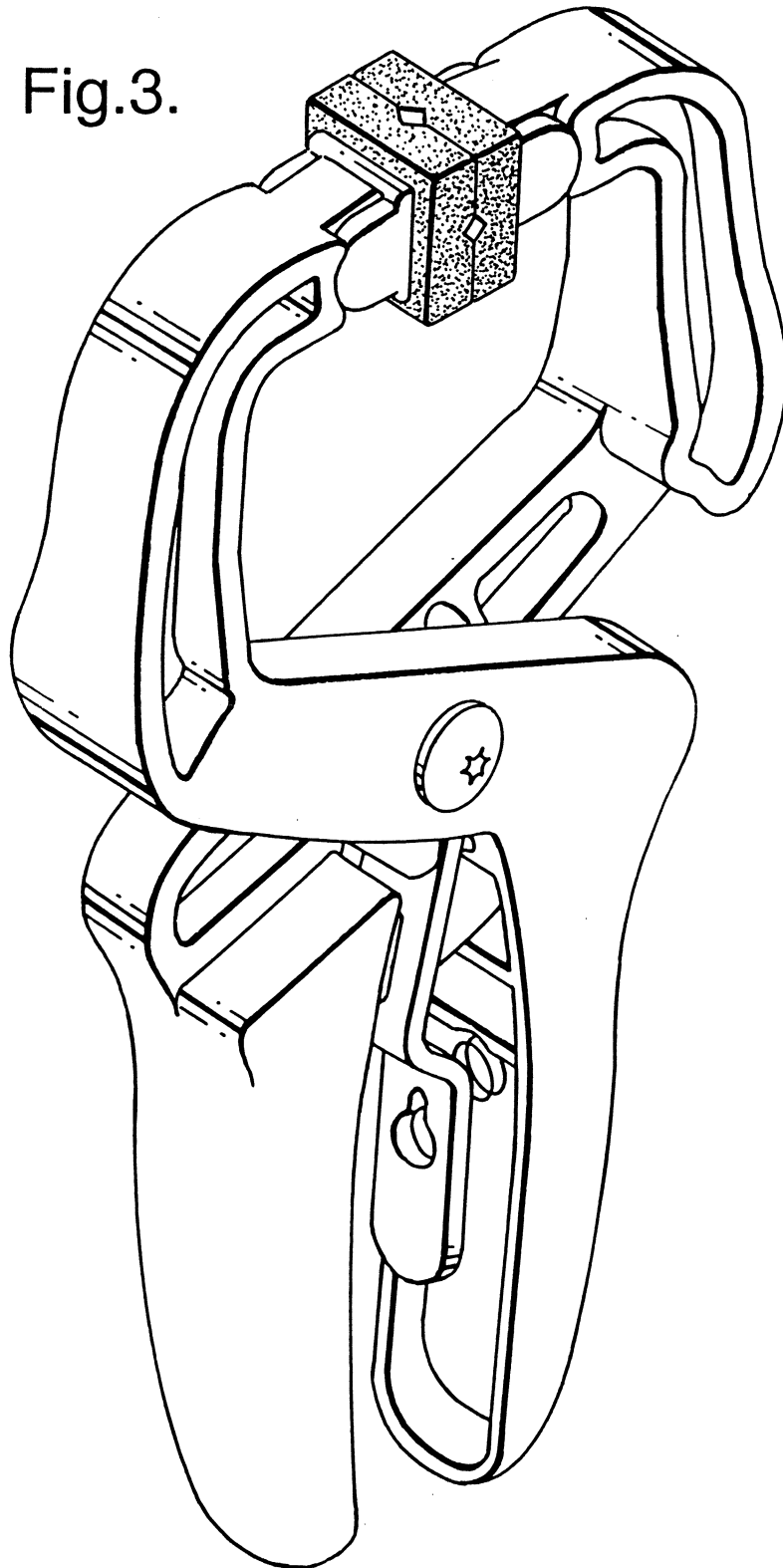

Fig.2.



[CANDIDATE No.....]

Fig.3.



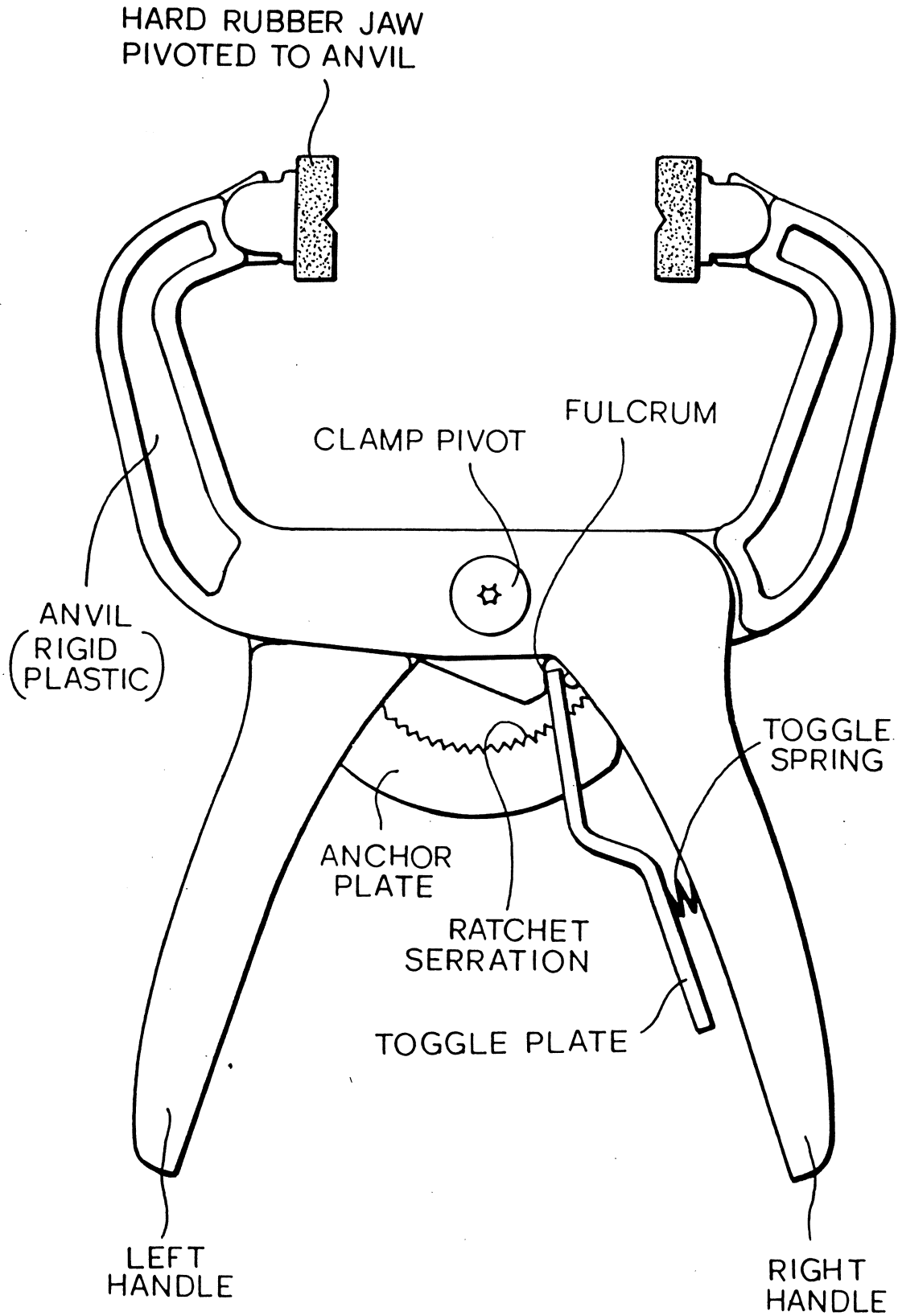

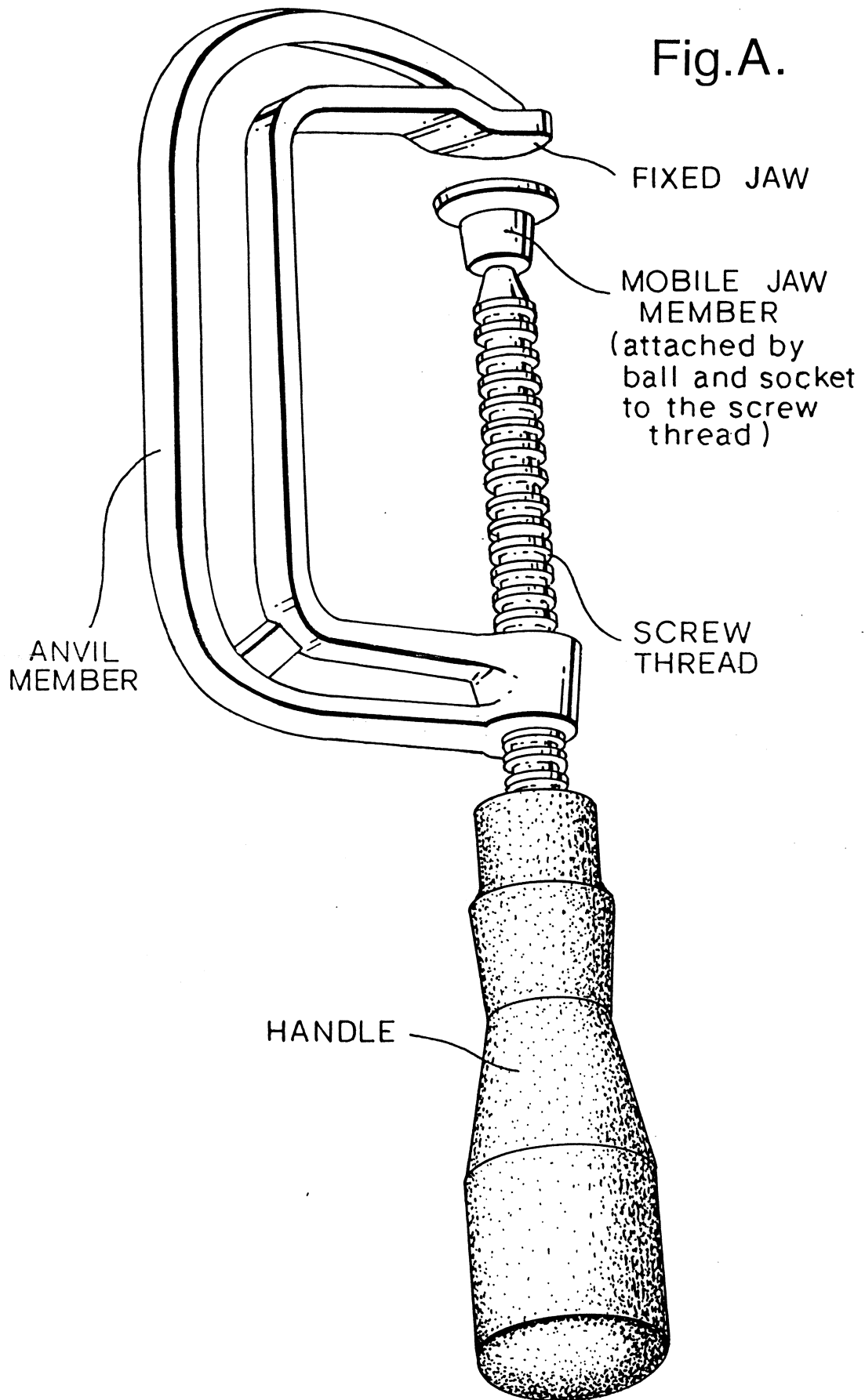

Fig.B.

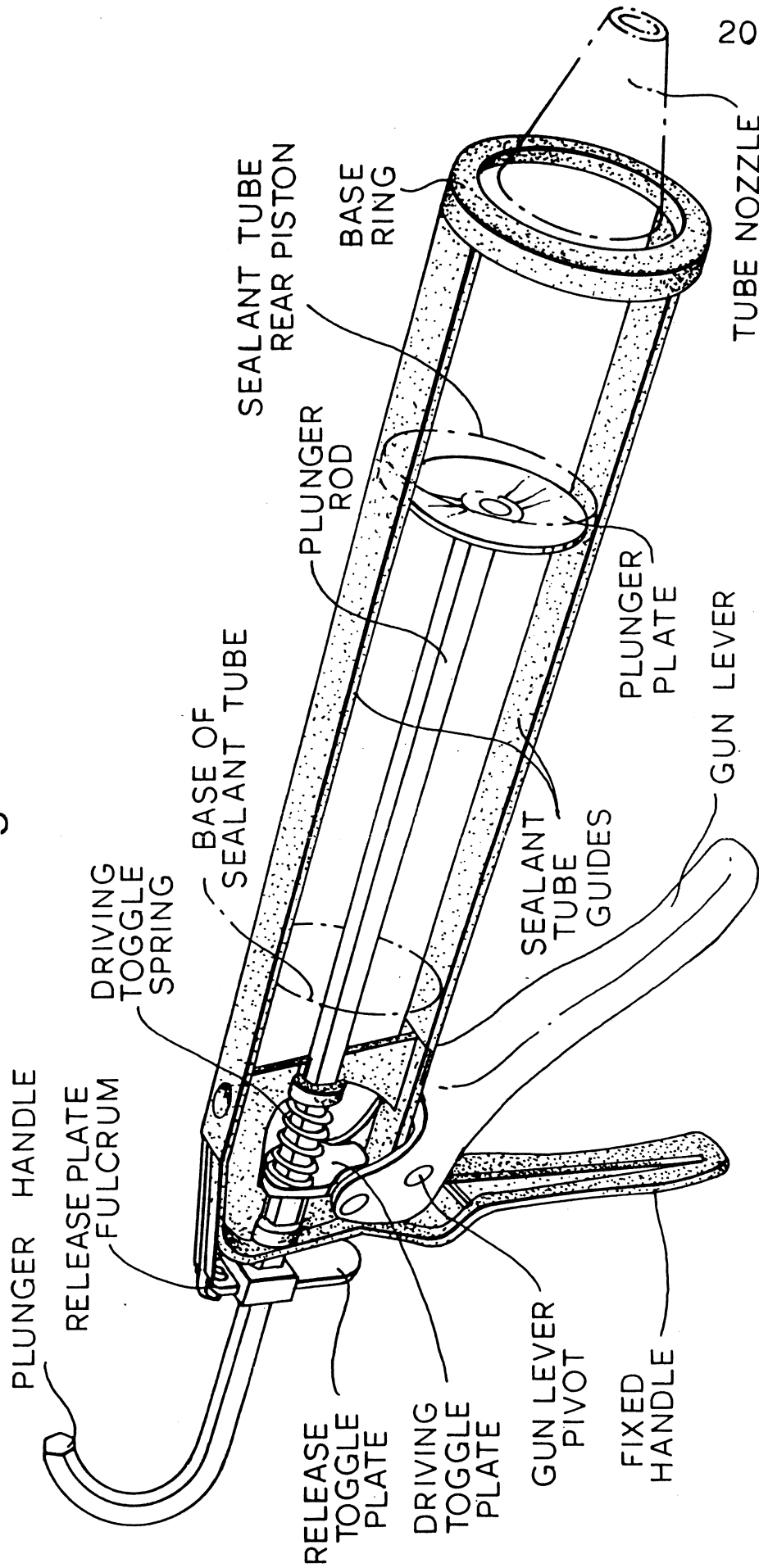
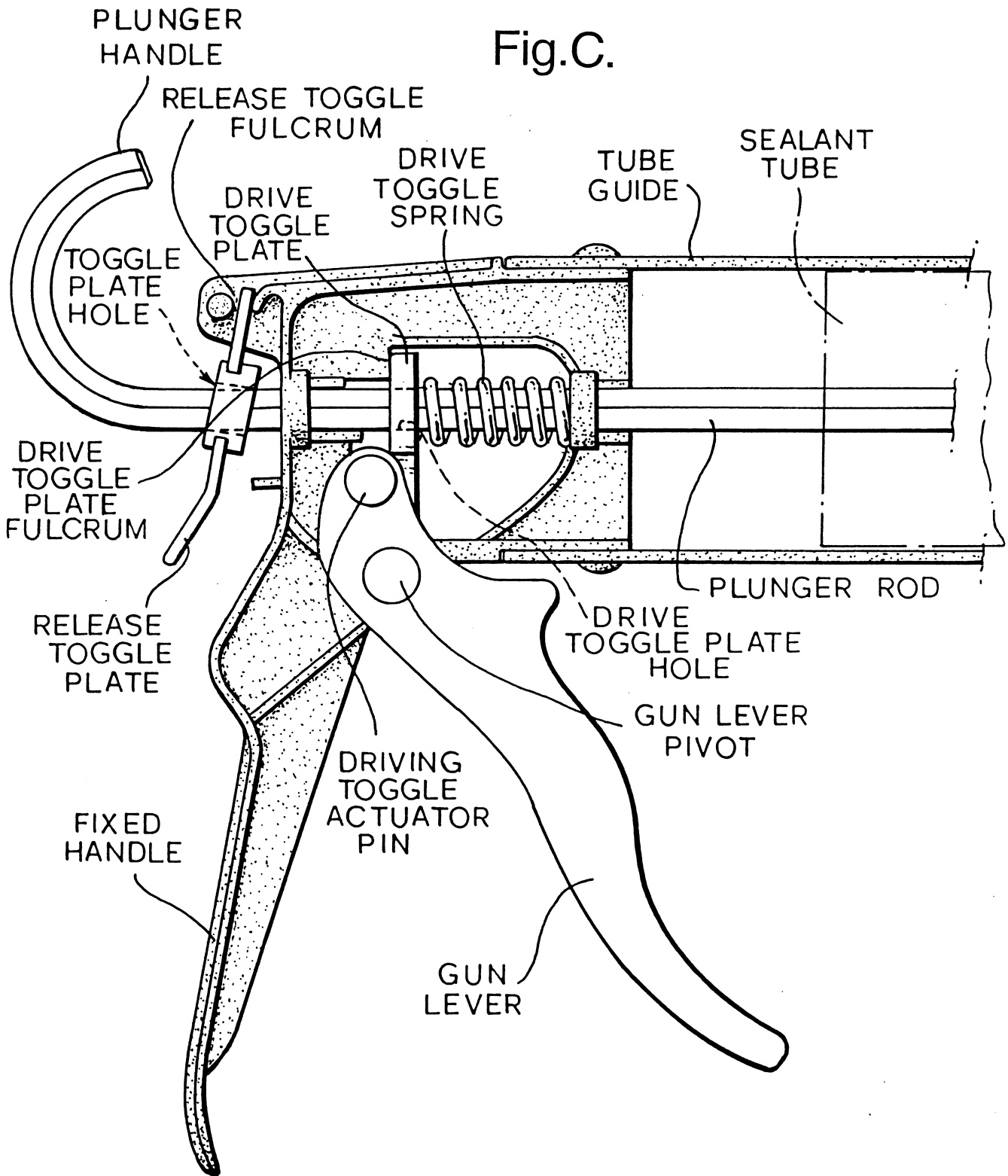

Fig.C.



## 2003 – P3 – EXAMINERS' COMMENTS (Final Form)

In this year's question, by far most candidates appreciated that invention could arguably lie in employing the principle of operation of the sealant gun to make a one-hand operated clamping device, and one which could be quick to use.

However, far too many candidates unnecessarily limited themselves claiming still what they saw, rather than the arguable invention. For basically this was along the lines:

"A clamping device having jaws and indexing (or toggle) (or ratchet) means arranged in use to hold the jaws closed and releasable to permit them to open."

A claim to such a clamping device in which the jaws are associated with handles pivotally attached one to another is accordingly deemed too narrow as is one in which the toggle has a hole through which the ratchet passes.

The Examiners do expect the candidate to know how to present the invention as to make it appear that there is indeed an inventive step with regard to the prior art. There was, in this instance, no need whatever to mention the sealant gun in the patent specification, and to do so presents a hostage to fortune when trying to convince a Patent Office Examiner that the claims are non-obvious. There was clear need to mention a g-clamp.

It will be seen above that a passable main claim could be very short. It was noticeable that by far most candidates claimed "a clamping device". Only one or two claimed a clamp. As most candidates did not go on to use the expression "clamping device" to cover for example both a clamp and a vice, there was perhaps little point in using two words where one would suffice.

By the same token, a large number of candidates, towards the end of their specific description, included a paragraph having the clause "other embodiments will occur to those skilled in the art" without giving even the slightest hint as to what such embodiments might comprise. This was the opportunity to suggest a vice and/or a linear clamp in which the handles were not pivotally attached if these alternatives occur to the candidate, otherwise it is better to say nothing!

A number of candidates also seemed not to appreciate that the specific description should be just that – specific – and that the use of general terms in this portion of the specification is not helpful. The best answers also started off the specific description by describing the components of the clamp and how they fitted together. The subsequent description of how the clamp was operated in practice then followed on logically and clearly.

Care is still needed in the drafting of the preamble, to reflect the actual facts. "G-clamps are known in the workshop and d-i-y world" is true, A "G-clamp has been postulated" is inaccurate. It is also, as a matter of fact, untrue that a G-clamp **cannot** be operated with one hand. If one has the fixed jaw and, perhaps, the anvil appropriately contacting the work piece it may be possible to use one hand. This of course means that a main claim will fail whose distinguishing feature from the prior art is one-handed operation. It is however generally true that the traditional G-clamp is slower to use than the clamp of the

invention. But it also happens to be the case that one can usually exert more pressure with a g-clamp than with the scissor clamp of this question. In other words the g-clamp does not have to be disparaged in order to show invention in the clamping device of the question. There does not always need to be a problem with the prior art that the invention is to solve; the invention may be an improvement over the prior art.

As usual, many candidates presented “notes to the Examiner”, some of which were quite long. These are rarely if ever useful. It is the preamble, the claims, the specific description and the abstract which earn the marks and the Examiners are well capable of determining from those whether the candidate is “fit to be let loose on the public in his own right”.

Turning to the Abstract, a minor point but worth a mark or two; it is not necessary to include the words “The present invention provides a” or “There is provided”. It is accepted practice to begin with the article (or method). In this case “A clamping device comprising ...” is a proper way to start.

One or two candidates presented method claims. These were deemed unnecessary, and candidates are reminded that they do not show their expertise by including method claims in such instances, just as they don’t, in this instance, by describing the sealant gun. The question is to be treated as a real life example.

Similarly, dependent claims should only relate to features which have a reasonable likelihood of distinguishing the invention patentably in the event that the subject matter of the main claim is found to be unpatentable. Although most candidates bore this in mind, a few answers contained several claims which related to unimportant features. The Examiners were looking for dependent claims principally directed to; handles, handles pivoted, handles pivoted intermediate their ends, pivoting jaws, hard rubber jaws, grooved jaws, spring loaded handles, spring loaded indexing.

Candidates are reminded that they make it difficult for themselves to pass if they do not attempt each part of the question. It is also good advice to write on every other line only – for clarity and to enable amendments to be made. If the claims are long, then it is a good idea to start each one on a new page.

This year no candidate evinced any inability to deal with the subject matter of the question and to describe the mechanical object adequately. Candidates passed or failed entirely on their ability professionally to present a good broad claim, to introduce it accurately and in such a way as to convince the reader that there is an invention present, and to describe specific embodiments accurately according to established custom.